

Development of a measurement and control system for a 10 kW@20 K refrigerator based on Siemens PLC S7-300

J Li^{1,2}, L Q Liu¹, T Liu³, X D Xu¹, B Dong¹, W H Lu¹, W Pan¹, J H Wu¹ and L Y Xiong¹

¹ Key Laboratory of Cryogenics, Technical Institute of Physics and Chemistry, Chinese Academy of Sciences, Beijing, 100190, China

² University of Chinese Academy of Sciences, Beijing 100049, China

³ Beijing Sciample Technology Co., Ltd., Beijing 100190, China

lqliu@mail.ipc.ac.cn

Abstract. A 10 kW@20 K refrigerator has been established by the Technical Institute of Physics and Chemistry, Chinese Academy of Sciences. A measurement and control system based on Siemens PLC S7-300 for this 10 kW@20 K refrigerator is developed. According to the detailed measurement requirements, proper sensors and transmitters are adopted. Siemens S7-300 PLC CPU315-2 PN/DP operates as a master station, two sets of ET200M DP remote expand I/O, one power meter, two compressors and one vacuum gauge operate as slave stations. Profibus-DP field communication and Modbus communication are used between the master station and the slave stations in this control system. The upper computer HMI (Human Machine Interface) is compiled using Siemens configuration software WinCC V7.0. The upper computer communicates with PLC by means of industrial Ethernet. After commissioning, this refrigerator has been operating with a 10 kW of cooling power at 20 K for more than 72 hours.

1. Introduction

Recently, a 10 kW@20 K refrigerator has been established by the Technical Institute of Physics and Chemistry, Chinese Academy of Sciences. This refrigerator designs to produce 10 kW of cooling power at 20 K. A measurement and control system based on Siemens PLC S7-300 for this refrigerator is being discussed in this paper. The sensors and actuators used in this control system are overviewed. The control logic and control strategy of this 10 kW@20 K refrigerator is also introduced briefly.

2. Description of the 10 kW@20 K refrigerator

The process flow diagram of this 10 kW@20 K refrigerator is shown in Figure 1. This 10 kW@20 K refrigerator consists of two main parts, i.e. the compressor station and the cold box. The compressor is composed of two screw compressors which are in parallel, an oil removal system (ORS), a helium buffer tank and a gas management valve panel composed of three room temperature valves, CV-1, CV-2 and CV-3. The cold box is a vacuum insulated cold box which contains two heat exchangers, the first stage heat exchanger HEX1 and the second stage heat exchanger HEX2 and two control cryovalves including a liquid Nitrogen (LN) supply valve CV-4, a turbine inlet valve CV-5, and a turbine. E-3 is a dummy load which provides a heat capacity of 10 kW. The selected compressor model is MAYEKAWA MYCOM HE250-KL. The whole helium gas mass flow rate is 400 g/s on the condition of suction pressure 4 bara and discharge pressure 20.5 bara. Each compressor provides half of that capacity.

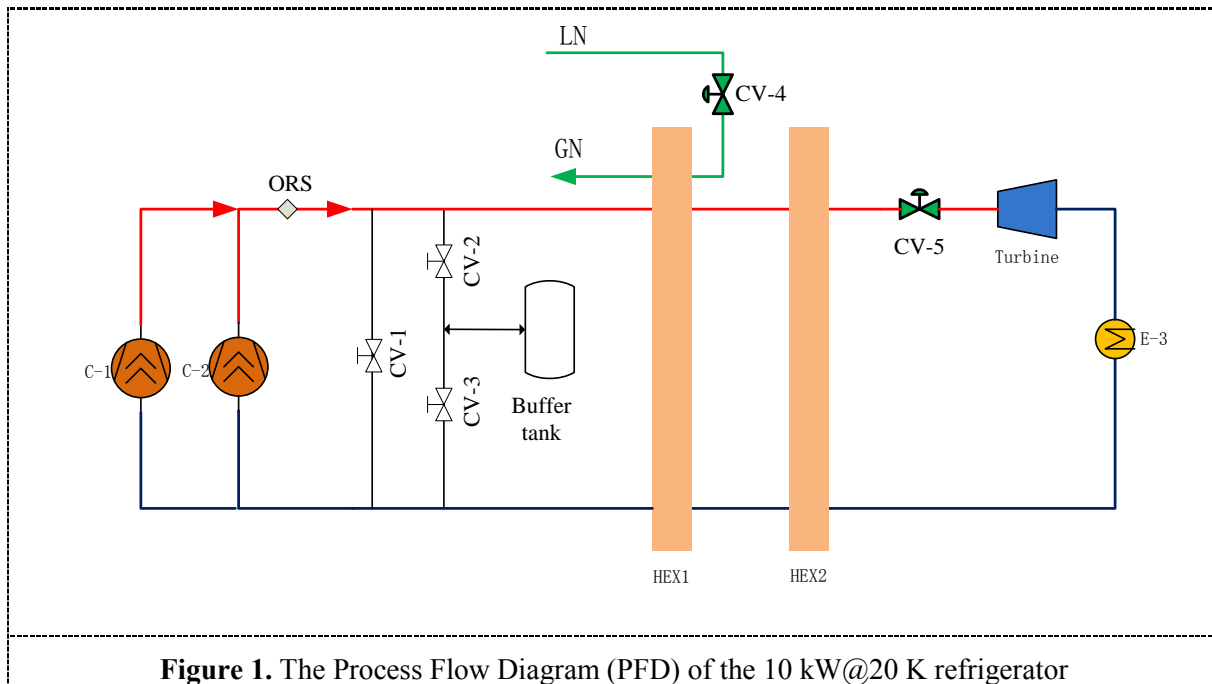

Figure 1. The Process Flow Diagram (PFD) of the 10 kW@20 K refrigerator

3. Overview of sensors and actuators of this 10 kW@20 K refrigerator

To measure temperature, pressure, flow rate of helium gas and rotary speed of the turbine, proper sensors and actuators are selected.

3.1. Temperature sensors and transmitters

There are 15 temperature sensors, including redundant ones in this 10 kW@20 K refrigerator, have been mounted at different locations. Redundancy is typically applied for thermometers that cannot be exchanged unless a major mechanical operation is undertaken [1]. There are two types of temperature sensors, Rhodium-iron resistance thermometers and Platinum (PT-100) temperature sensors. Both Rhodium-iron resistance thermometers and Platinum (PT-100) temperature sensors are calibrated by the Centre of Cryogenic Metrology. The calibrated accuracy of each Rhodium-iron thermometer from 1.2 K to 300 K is 0.1 K. The calibrated accuracy of PT-100 from 77 K to 323 K is ± 0.1 K. All the temperature sensors have their own specific data table.

11 Rhodium-iron thermometers have been used to monitor the temperatures from 1.2 K to 300 K. Because Rhodium-iron thermometers have non-linear resistance-temperature characteristics, the measured resistance is converted into temperature by performing interpolation on calibration data. The model 211S single channel temperature transmitter (230 VAC supply) from Lakeshore Inc. has been used for operating with these 11 Rhodium-iron thermometers. Output signal of the model 211S is 4~20 mA, which is transmitted to the Siemens PLC analog input model SM331.

4 Platinum (PT-100) temperature sensors are used for monitoring the temperatures from 77 K to 323 K. Resistance Temperature Detector (RTD) model SM331 of the Siemens PLC analog input is used for operating with these Platinum (PT-100) temperature sensors. SM331 is an eight channel analog input model with individual temperature signals. The resolution of the SM331 RTD model is 15 bits.

The four-wire technique is used in the transmitters for measurement of all these temperature sensors (Rhodium-iron thermometers and PT-100).

All the sensors are mounted on the cold surfaces using an in-house designed copper housing block, glued with low temperature varnish to achieve good thermal contact with surfaces, and covered with multi-layer super insulation (MLI) to avoid direct radiation heat load on the sensors. Thermal anchoring of the sensor wires has been done on the surfaces to minimize error due to heat flow from the leads to the sensors.

The detailed distribution of temperature sensors and transmitters in this 10 kW@20 K refrigerator is given in Table 1.

As Table 1 shows, there are two sets of Rhodium-iron thermometers on the outlet of the turbine. One set of Rhodium-iron thermometers (two pieces, one is active and the other one is standby) are mounted on the straight pipe of turbine diffuser. The other set of Rhodium-iron thermometers (two pieces, one is active and the other one is standby) are mounted on the straight pipe which is downstream of the turbine diffuser's straight pipe.

Table 1. Distribution of temperature sensors in this 10 kW@20 K refrigerator

No.	Type	Location	Transmitter	Quantity
1	Rhodium-iron	Inlet of turbine	Model 211S temperature transmitter	2
2	Rhodium-iron	Outlet of turbine, on the straight pipe of turbine diffuser	Model 211S temperature transmitter	2
3	Rhodium-iron	Outlet of turbine, on the straight pipe which is downstream of the turbine diffuser's straight pipe	Model 211S temperature transmitter	2
4	Rhodium-iron	Inlet of dummy load	Model 211S temperature transmitter	1
5	Rhodium-iron	Outlet of dummy load	Model 211S temperature transmitter	2
6	Rhodium-iron	Inlet of the second stage heat exchanger HEX2 (low pressure side)	Model 211S temperature transmitter	2
7	PT-100	Outlet of the first stage heat exchanger HEX1 (high pressure side)	RTD analog input model SM331	1
8	PT-100	Inlet of the first stage heat exchanger HEX1 (low pressure side)	RTD analog input model SM331	1
9	PT-100	Outlet of the first stage heat exchanger HEX1 (low pressure side)	RTD analog input model SM331	1
10	PT-100	Outlet of the Liquid Nitrogen precooling pipe	RTD analog input model SM331	1

3.2. Pressure transmitters and the other sensors/actuators

The pressures are measured by ColliHigh™ JYB-KO-HAA pressure transmitters with $\pm 0.2\%$ full scale accuracy. Some important positions' pressures, for example, the pressure of buffer tank, the suction pressure and the discharge pressure of the compressors, the Liquid Crystal Display (LCD) pressure transmitters are used for local display.

The flow rate of helium gas is measured by vortex flowmeter. The temperature measurement point and the pressure measurement point are set on the downstream of the vortex flowmeter to perform the temperature and pressure compensation.

The rotation speed of the turbine is measured by an in-house designed tachometer. The measuring range is 0~100,000 RPM. The accuracy is better than $\pm 0.01\%$.

Nine sets of valves including three room temperature valves and six cryovalves from WEKA AG. are adopted as actuators. The bypass room temperature valve CV-1, the Liquid Nitrogen (LN) supply valve CV-4 and the turbine inlet valve CV-5, all of them have position feedback signal.

4. Measurement and control system based on Siemens PLC S7-300

There are three types of communication protocols in this measurement and control system, i.e. Profibus-DP communication protocol, Modbus protocol and industrial Ethernet communication protocol. CPU315-2 PN/DP is as the master station. Two sets of ET200M and one vacuum gauge are as the slave stations of Profibus-DP field communication protocol. The upper computer communicates with PLC CPU by means of industrial Ethernet. The compressor C-1, compressor C-2 and the power meter of the

dummy load communicate with PLC CPU through Modbus communication protocol. The control structure of this measurement and control system is shown in Figure 2.

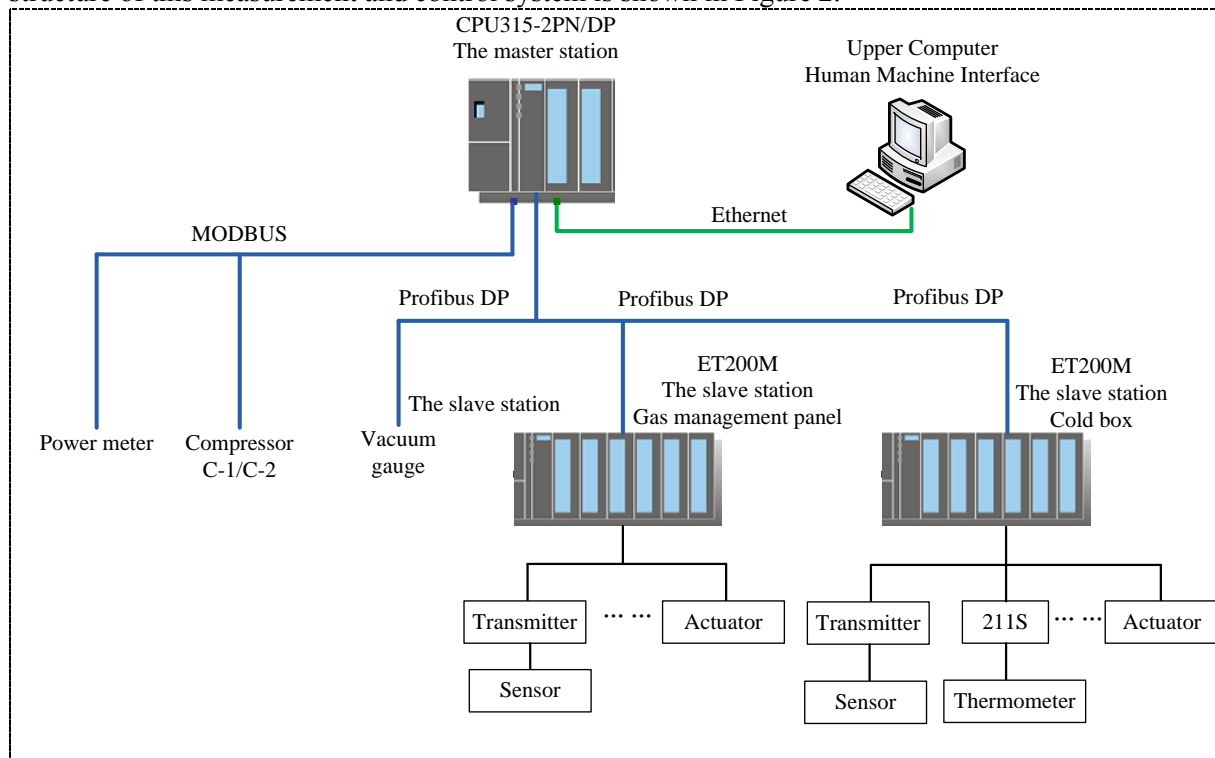

Figure 2. The control structure of the 10 kW@20 K refrigerator

The HMI (Human Machine Interface) is compiled using SIEMENS software WinCC V7.0. Figure 3 shows the HMI of the cold box. The WINCC HMI system has many functions which include not only graphic pages, monitoring, adjusting the process parameters, controlling, but also real time and historical trending, alarms and events. The programming language for this control system is SIEMENS software Step 7 V5.5.

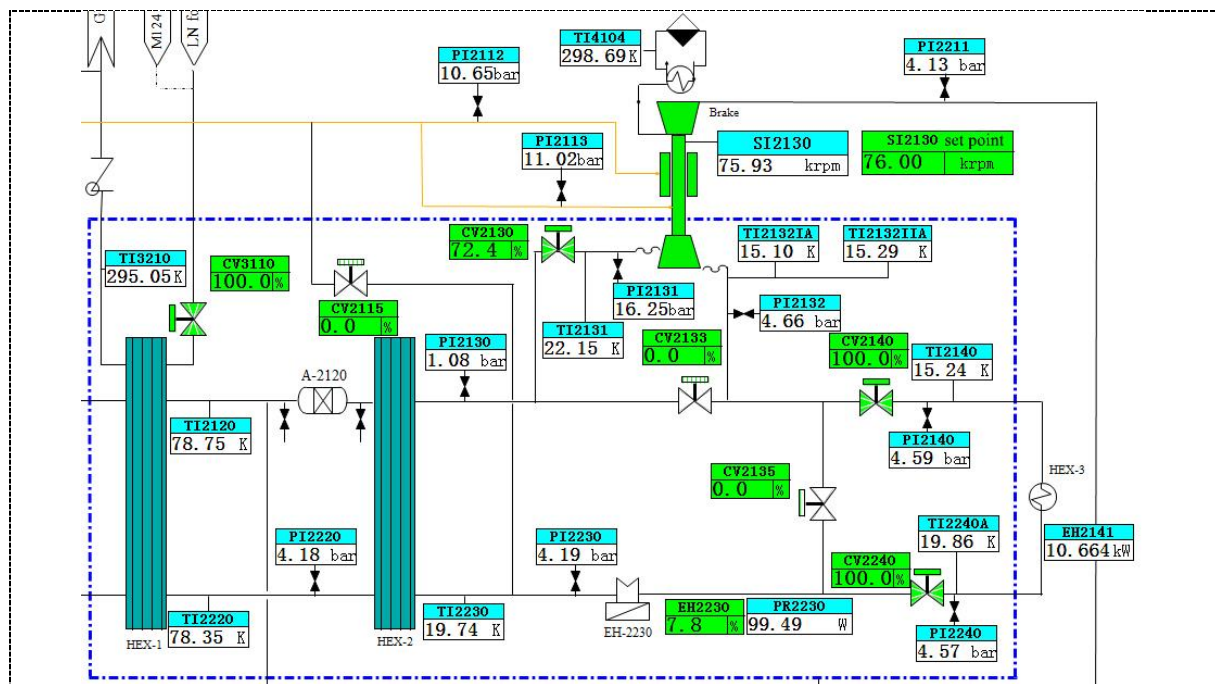

Figure 3. The HMI (Human Machine Interface) of the cold box of the 10 kW@20 K refrigerator

5. Control strategy and control logic

According to the different operating modes of this 10 kW@20 K refrigerator, the control strategy and control logic are proposed. The sequential control and control loops which are mainly implemented through standard PID (Proportional, Integral and Derivative) controllers are adopted in this measurement and control system. The control logic of suction pressure and discharge pressure of compressors is the traditional control logic [2]. The bypass valve CV-1 controls the suction pressure of compressors. The discharge valve CV-2 and the charge valve CV-3 control the discharge pressure of the compressors. There is a PID relationship between the position feedback signal of the bypass valve CV-1 and the frequency of the first compressor C-1.

Figure 4 shows the control logic of the cold box of this 10 kW@20 K refrigerator. In figure 4, the rotation speed of the turbine S is controlled by the inlet valve of turbine CV-5. The outlet temperature of the LN precooling pipe is controlled by the Liquid Nitrogen (LN) supply valve CV-4. Inlet temperature of the second stage heat exchanger HEX2 (low pressure side) Tr is controlled by the electrical heater EH.

The commissioning process of this control system for this 10 kW@20 K refrigerator is as follows,

- First, all the measurement points should be verified;
- Second, the compressor station is commissioned;
- The next, the whole control loops will be commissioned;
- The manual modes should be tested firstly, then the automatic modes will be added.

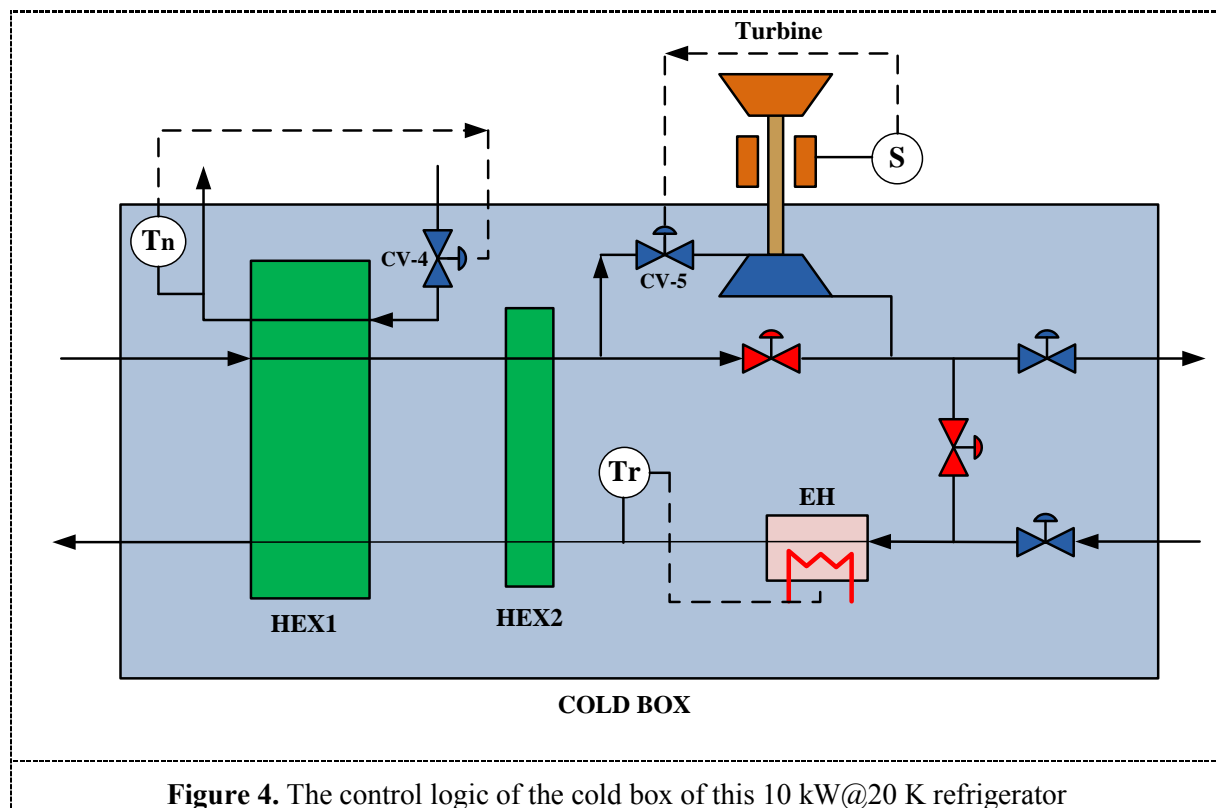

Figure 4. The control logic of the cold box of this 10 kW@20 K refrigerator

6. Commissioning result of this 10 kW@20 K refrigerator

After commissioning, this refrigerator has been operating with a 10 kW of cooling power at 20 K for more than 72 hours. Figure 5 shows the 72 hours' operation trend of the inlet temperature of the second stage heat exchanger HEX2 (low pressure side) Tr.

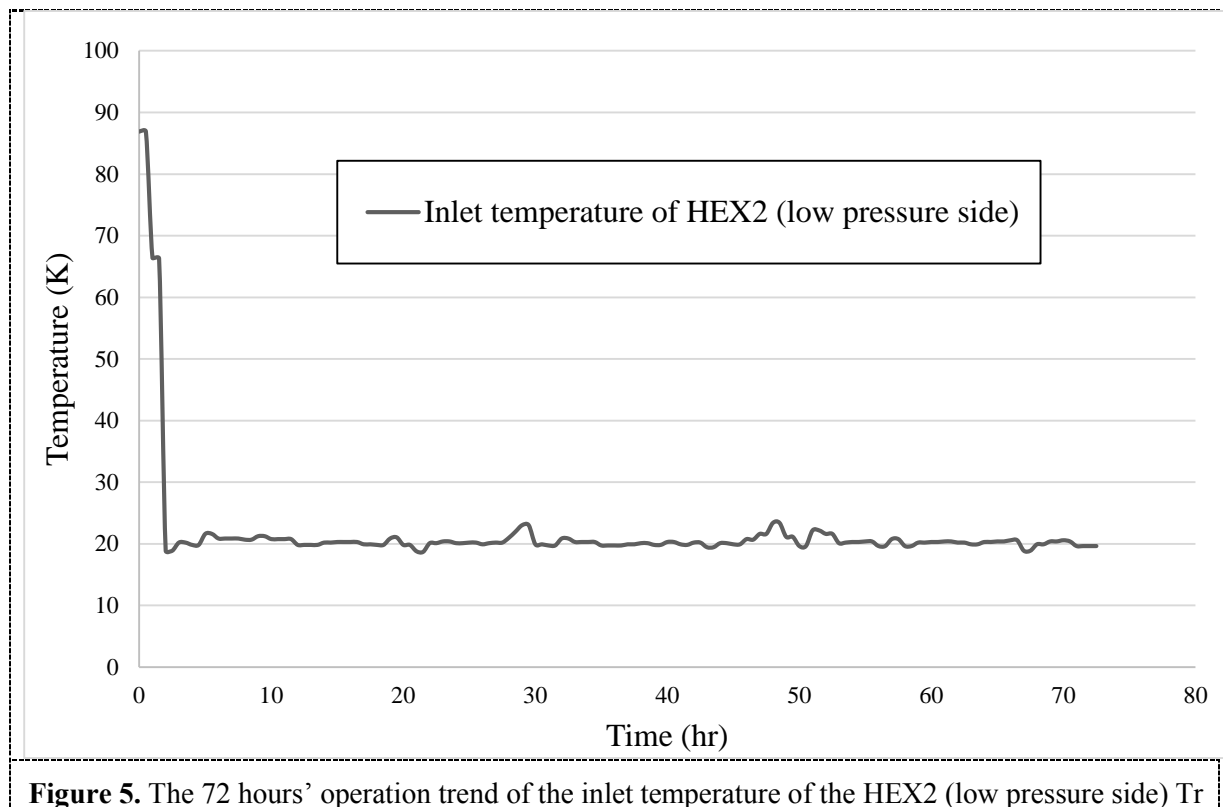

Figure 5. The 72 hours' operation trend of the inlet temperature of the HEX2 (low pressure side) Tr

7. Conclusion

A 10 kW@20 K refrigerator has been established by the Technical Institute of Physics and Chemistry, Chinese Academy of Sciences. A measurement and control system based on Siemens PLC S7-300 for this 10 kW@20 K refrigerator has been introduced. The sensors/transmitters, the control logic and control strategy of this measurement and control system are discussed. In the next future, the development of a 250 W@4.5 K refrigerator has been put on the agenda by the Technical Institute of Physics and Chemistry, CAS. Then a corresponding measurement and control system will be proposed soon.

References

- [1] Vauthier N, Avramidou R, Balle Ch, Casas-Cubillos J, Ciechanowski M, Fernandez-Penacoba G, Fortescue-Beck E, Gomes P, Jeanmonod N, Lopez-Lorente A and Suraci A 2007 First experience with the LHC cryogenic instrumentation *Advances in Cryogenic Engineering: Transactions of the Cryogenic Engineering Conference-CEC* vol 53 ed J G Weisend II (Chattanooga Tennessee: American Institute of Physics) pp 957 – 964
- [2] Li J, Liu L Q, Xu X D, Liu T, Li Q, Hu Z J, Wang B M, Xiong L Y, Dong B and Yan T 2015 Development of a measurement and control system for a 40 l/h helium liquefier based on Siemens PLC S7-300 *Physics Procedia* vol 67 pp 1181 – 1186

Acknowledgments

This work is supported by the Key Laboratory of Cryogenics, TIPC, CAS (CRYOQN201307).